

APOGEE™ Drive Self-Powered CPU Waterblock



 Designed in the USA
One or more Patents Pending

DISCONTINUED

8-4-07

Introduction

ap·o·gee: The farthest or highest point; the apex; a final climactic stage

In the world of water-cooling, the Apogee™ CPU Waterblocks and MCP350 pumps have become legends, proving themselves to be among the best available to the enthusiast and professional users alike.

Enter the patent pending **Apogee™ Drive 350** self-powered series of waterblocks which consolidate both technologies into one convenient package capable of handling today and tomorrow's most extreme processors on the market.

From a technological standpoint, the Apogee Drive combines the best characteristics of both products:

- Derived from the MCP350 pump:
 - Small form factor
 - High Reliability
 - High head pressure
 - Quiet operations
- Derived from the Apogee™ water-block
 - Low thermal impedance
 - Low pressure drop

From the user standpoint, the Apogee Drive provides the following direct benefits:

- Extreme simplicity of installation

Contents

- [Performance data](#)
- [Motherboard & CPU compatibility](#)
- [Specifications](#)
- [MSRP & parts](#)

Installation Guide

[Multilingual Installation Guide](#)

Apogee Drive Priming Precautions

English, French, German, Spanish

Related Products



[Apogee™ GT](#)



[Apogee™ -1U Server](#)



[Apogee™-1U 775](#)



[MCW60 VGA Cooler](#)

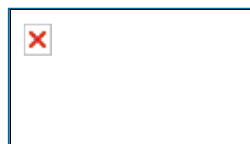

[MCW-Ramcool VGA memory cooler](#)

- True High Performance characteristics
- Substantial cost savings

In parallel to the Apogee Drive, we have also developed a new line of radiators featuring an integrated reservoir. This allows us to offer a revolutionary high performance liquid cooling kit composed of two components only: the H2O-Compact series.

Performance data



MCW30 Chipset Cooler

Product Reviews

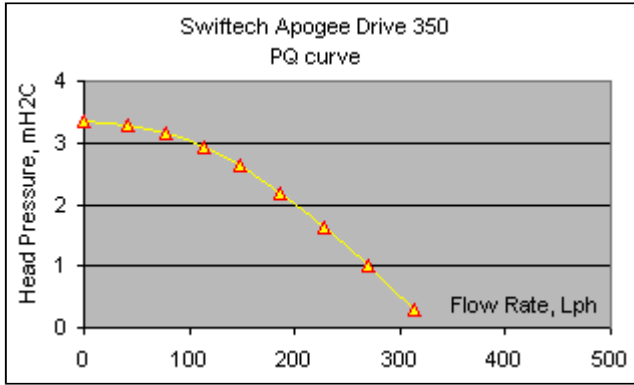

With the 10 ft (over 3m) of head pressure produced by its motor, the Apogee™ Drive is also capable of sustaining high flow rates in complex loops where chipset(s), and single or dual VGA are also liquid cooled.

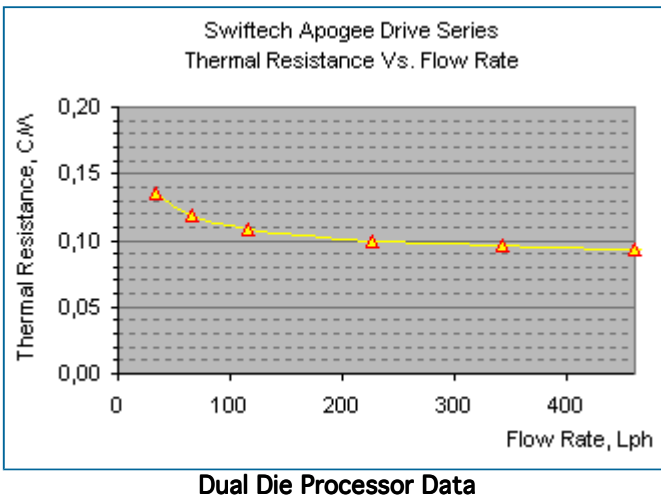
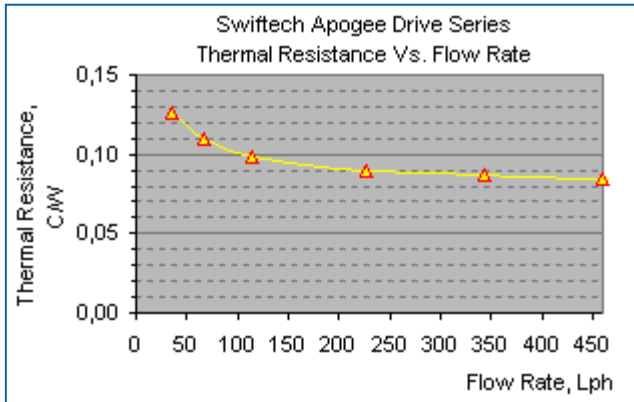

[Back to top](#)

Motherboard and CPU Compatibility

The Apogee™ Drive is compatible with the following processors:

- Socket 775 (Pentium® 4, Core Duo, Core 2 Duo, Extreme),
- Socket 754, 939, 940 (AMD® 64 bit processors)
- Socket AM2 (AMD® 64 bit processors)
- Socket F (AMD®)

Specifications

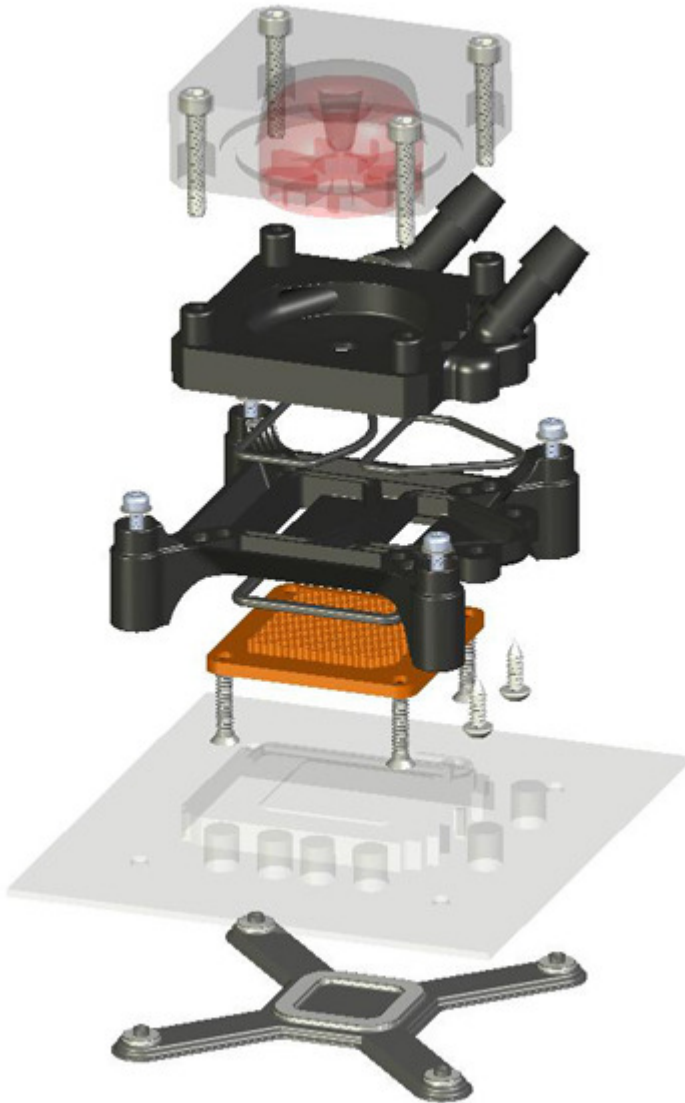

Exploded view

- Internal structure: the CNC machined C110 copper base plate is at the heart of Apogee™ Drive thermal efficiency. Designed
-

using Computational Fluid Dynamics, the Patent Pending Diamond Pin Matrix is optimized to increase wet surface area, coolant velocity, while minimizing pressure drop.

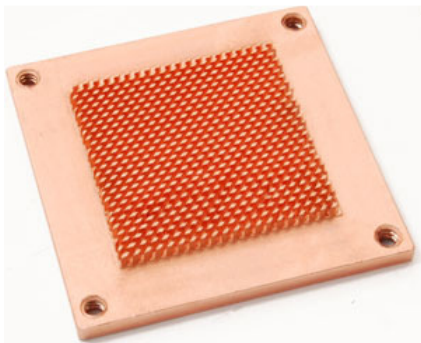

Patent Pending Diamond Pin Matrix Copper base plate
identical to that of the Apogee™ GT

- The patent pending housings are injection molded for mass production and economies of scale.
- The Pump housing, internals, and specifications derive from the MCP350 pump:
 - Motor: Electronically commutated, brushless DC, spherical motor.
 - Nominal Voltage: 12 VDC
 - Nominal current: .69A to 1A
 - Nominal Power: 8.3 to 12W
 - Head Pressure: 10.8 ft (3.3 mH2O)
 - Flow Rate: 1.45 gpm (330 Lph)
 - MTBF (Mean Time Between Failures) 50,000 Hours.
- Thermal Design: Diamond Pin Matrix copper base plate.
- Fittings Style: Built-in 3/8" (10mm) barbs fittings.
- Weight: 10.1 oz (285 g)



APOGEE DRIVE

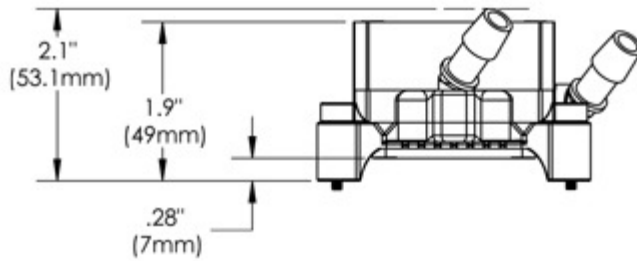
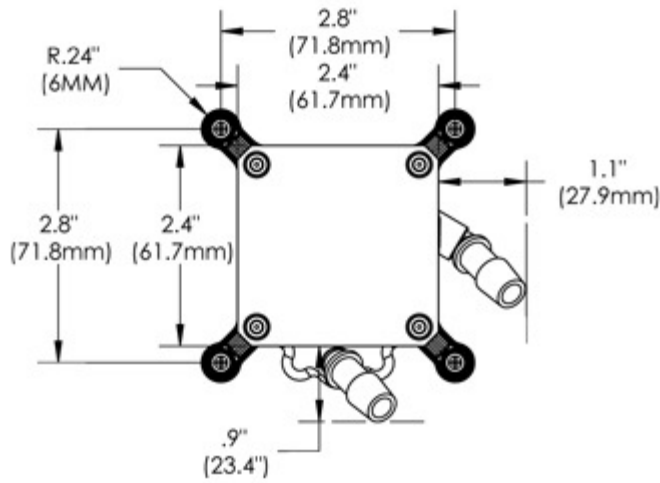

[Back to top](#)

MSRP & Parts

Please consult your Swiftech distributor prior to ordering direct from us, or purchase the product factory direct [here](#)

Product Information		
Part #	Description	Price
Apogee™ Drive	Assembly including water-block with pre-configured mounting for All Intel® socket 775 compatible processors, and separate hardware for all AMD® socket 754, 939, 940, AM2, and Socket F compatible processors, Arctic Céramique thermal paste, installation guide	\$99.95

[Back to top](#)